

ツースシリーズ

コイル回転形クラッチ

一部受注生産品

TR-2 5 10 15 20 40 80 280 560 1120

型 式	TR-2	TR-5	TR-10	TR-15	TR-20	TR-40	TR-80	TR-280	TR-560	TR-1120
定格トルク Nm	20	50	100	150	200	400	800	2800	5600	11200
定格電圧 DC-V	24	24	24	24	24	24	24	24	24	24
消費電力 W(at75°C)	13	20	26	34	42	47	47	71	78	93
質 量 kg	0.40	0.90	1.5	2.5	4.1	6.8	12	17	27	60

(注) TR-1120形は受注生産品です。

スプラインアダプタ取付穴位置

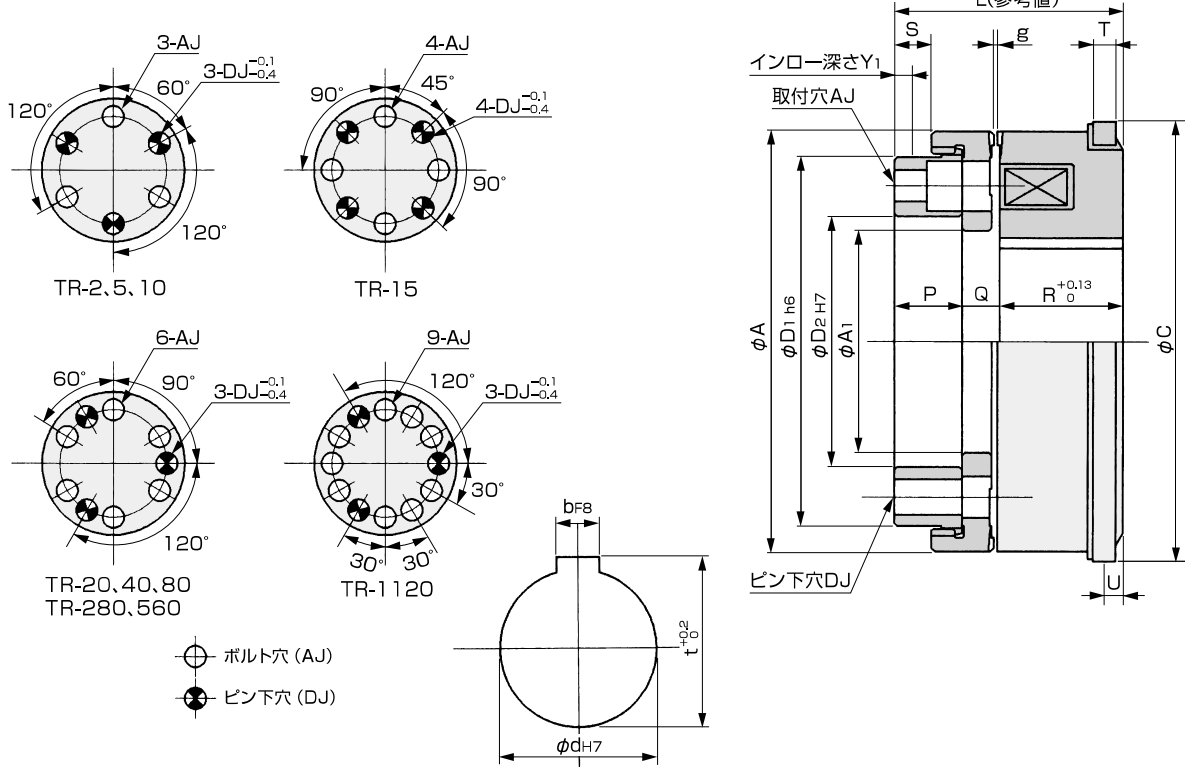

● ボルト穴 (AJ)
● ピン下穴 (DJ)

単位 : mm

型 式	TR-2	TR-5	TR-10	TR-15	TR-20	TR-40	TR-80	TR-280	TR-560	TR-1120
径 方 向	A	50.8	76.2	85.9	98.6	117.4	137.7	162.6	195.1	223.5
	A ₁	15.9	38.1	44.4	52.3	62	71.4	85.9	98.6	111.3
	C	52.3	77.7	90.5	104.8	122.2	142.9	168.3	200	230
	D ₁	44	64	73	86	103	118	144	173	197
	D ₂	25	42	50	58	70	84	104	118	140
軸 方 向	L	37.6	39.9	45.2	54.6	64.3	76.2	90.9	104.9	117.4
	P	8.6	11.2	12.7	15.7	19	22.4	28.4	28.4	28.4
	Q	7.1	7.8	7.74	9.56	10.63	12.53	14.01	17.38	21.52
	R	21.9	20.9	24.76	29.34	34.67	41.27	48.49	59.12	67.48
	S	4.5	5.3	6.6	9.4	10.4	13.8	16.8	8.6	8.6
取 付	T	6.3	6.3	6.3	6.3	6.3	8	8	8	8
	U	3.9	5.1	5.1	5.1	5.1	5.6	5.6	6.2	6.2
	Y ₁	2	3	3	4	5	6	8	7	10
	g	0.2 ^{+0.1}	0.3 ^{+0.2}	0.3 ^{+0.2}	0.4 ^{+0.3}	0.4 ^{+0.3}	0.4 ^{+0.3}	0.5 ^{+0.3}	0.8 ^{+0.3}	0.8 ^{+0.3}
	AJ	ピッチ円直径	35	53.74	62.48	72.9	86.86	101.6	124.46	146
ボルト穴		φ3.4穴 φ6.5座グリ 深さ4	φ5.5穴 φ9座グリ 深さ6.5	φ5.5穴 φ9座グリ 深さ6.5	φ6.5穴 φ11座グリ 深さ7.5	φ8.8穴 φ14座グリ 深さ10	φ8.8穴 φ14座グリ 深さ10	φ11穴 φ17.5座グリ 深さ13	φ14穴 φ20座グリ 深さ13.5	φ14穴 φ20座グリ 深さ13.5
DJ	ピッチ円直径	35	53.74	62.48	72.9	86.86	101.6	124.46	146	170
	ピン下穴	4	6	6	8	10	10	13	13	13
軸 穴	d	12	32	37	42	52	62	72	82	97
	b	4	10	10	12	15	18	20	24	28
	t	13.5	35.5	40.5	45.5	57	68	78	90	106

励磁作動形クラッチ／ブレーキ